

QUICKSAND

Operational Guide

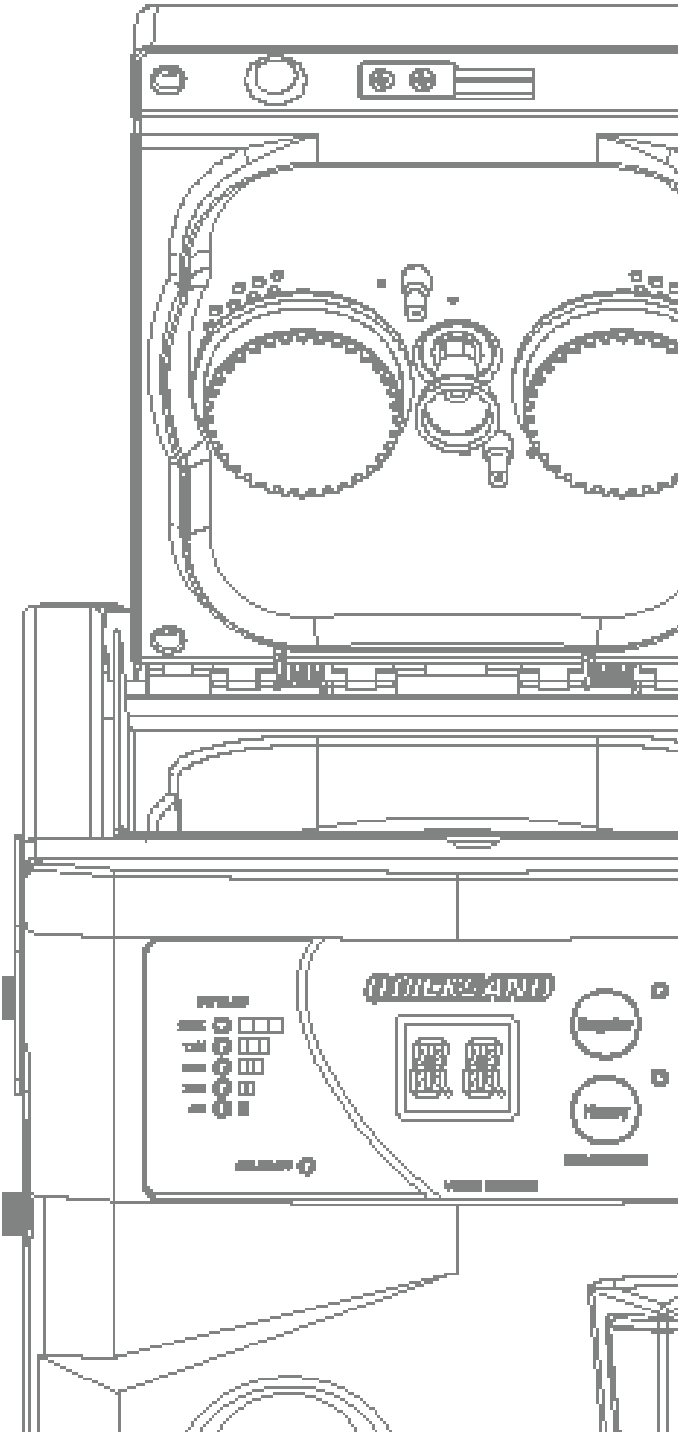

Reface Industries, Inc
107 Kew Street
Welshpool, WA 6061
1800733223
reface.com.au

THANK YOU

For purchasing the VMI QuickSand™

This unit is intended to sand the following discs: CD-ROMs, Music CDs, Data CDs, DVDs, HD-DVDs, Computer Discs, Game Discs, Books on disc, all recordable CDs and DVDs, and double-sided discs.

SAVE ALL PACKING MATERIALS. FAILURE TO USE PACKAGING DESIGNED FOR THIS UNIT MAY CAUSE DAMAGE TO THE UNIT AND WILL VOID WARRANTY. FOR MORE INFO CONTACT SUPPORT@VENMILL.COM.

© 2014 VenMill Industries, Inc. All rights reserved. Under the copyright laws, this manual may not be copied, in whole or in part, without the written consent of VenMill.

Every effort has been made to ensure that the information in this manual is accurate. VenMill is not responsible for printing or clerical errors.

Names and designs are trademarks of VenMill Industries, Inc. Artwork and Design © 2014 VenMill Industries, Inc. All Rights Reserved.

CAUTION: Units and consumables are designed for use in specific regions. Your warranty will be voided if you purchase the equipment and/or consumables outside of your designated region. Purchase only through Authorized Distributors found on our website at www.venmill.com. If uncertain, please contact sales@venmill.com.

READ BEFORE OPERATING EQUIPMENT

SECTION 1

Unpacking4

SECTION 2

Getting to Know Your Unit5

SECTION 3

Initial Setup.....7

SECTION 4

Quick Start10

SECTION 5

Modes of Operation.....12

SECTION 6

Notifications.....13

SECTION 7

Standard Maintenance14

 How to Replace the Sanding Pads14

 How to Clean the Filter14

 How to Replace the Foam Pads15

 How to Clean the Water Reservoir16

 How to Replace the Center Hub17

 How to Replace the Consumable Counter Chip (CQ Chip)18

 How to Replace the Jet Nozzle Extenders18

 How to Clean the Catch Tray19

 What to do when the QuickSand will not be used for a long period of time.....19

SECTION 8

Repacking20

SECTION 9

FAQs21

SECTION 10

Specifications23

Unpacking

SAVE ALL PACKING MATERIALS. Failure to use packaging designed for this unit will cause damage to the unit and will void warranty.

Parts that need to be saved are as follows:

1. VMI Quicksand Shipping Box
2. Top Cardboard Insert
3. Left & Right Side Packing Foams
4. Protective Plastic Bag

There is a charge for replacement packing materials (plus S & H).

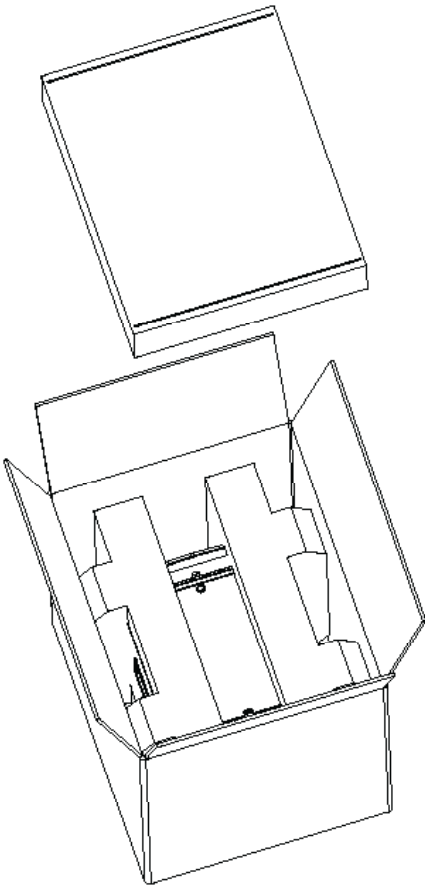

1. Open the Shipping Box.
2. Remove the Top Cardboard Insert - which contains the machine's starter supplies, accessories, and support documents.
3. Remove the VMI Quicksand from the shipping box.
4. Remove the Left and the Right side packing foams.
5. Take the VMI Quicksand out of the protective plastic bag.

Getting to know your unit

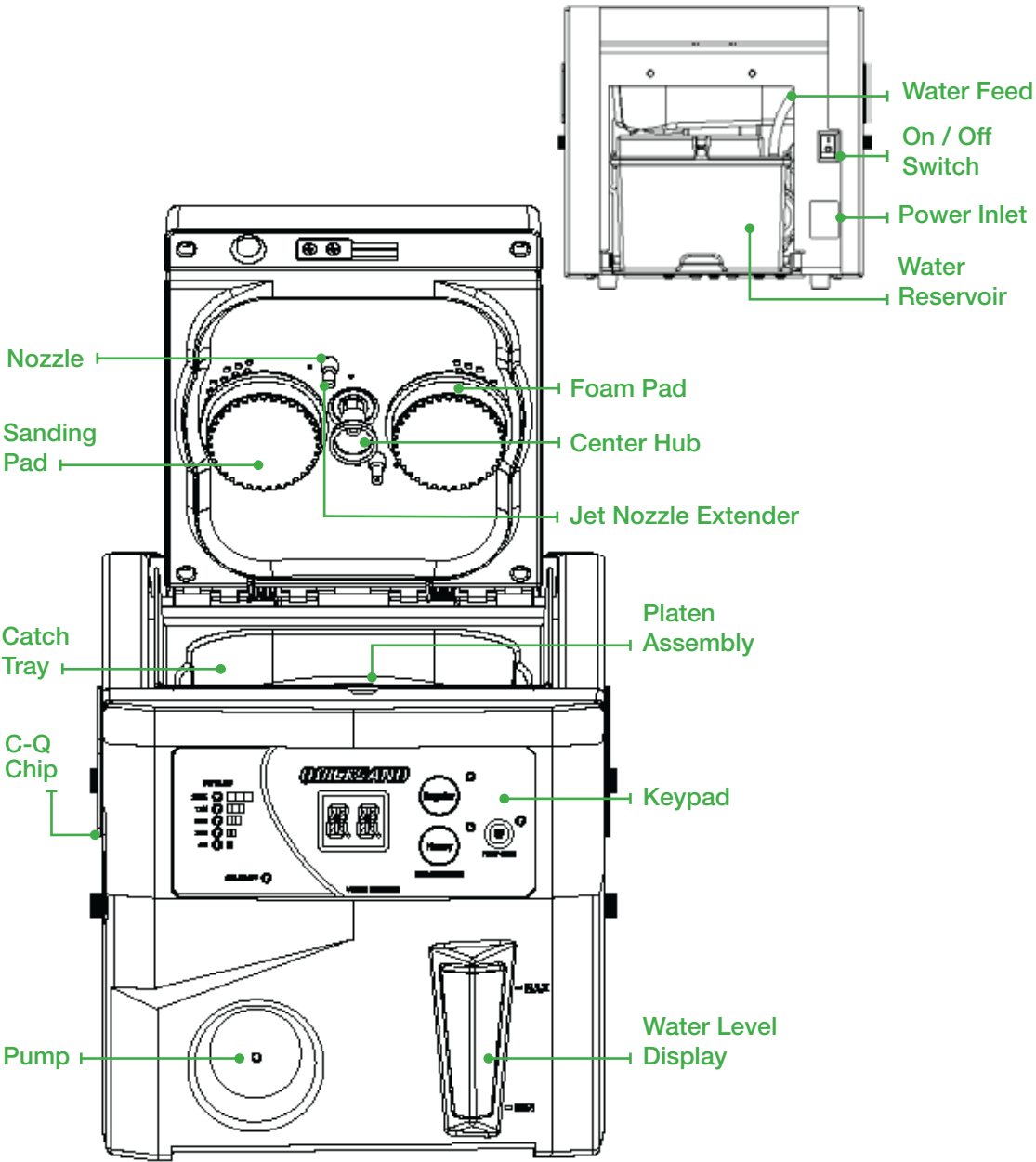

Getting to know your unit ... continued

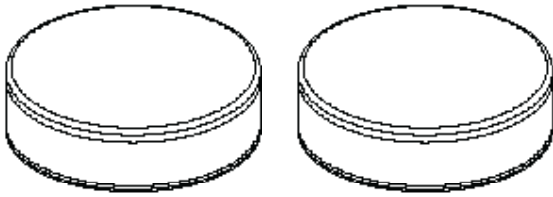

Foam Pads:

100 minutes of operation

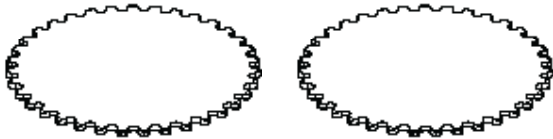

Sanding Pads:

25 minutes of operation

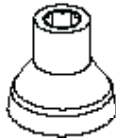

Center Hub:

Replace at every "RC" message

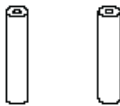

Jet Nozzle Extender:

Replace at every "RC" message.

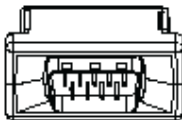

CQ Chip:

100 minutes of operation

(A starter CQ Chip of 50 minutes is included with your QuickSand.)

1. Install Counter Chip:

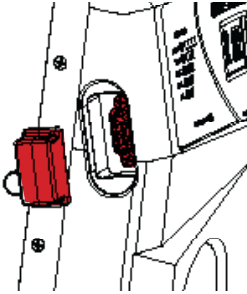

Locate the RS232 port on the front left hand side of the machine.

Take the CQ Chip, which has been provided with your machine, and install it into this port.

The Quicksand unit will recognize this chip, once the machine is powered on.

2. Install Power Cord:

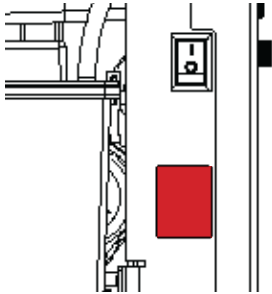

Insert the power cord into the power inlet on the back of the machine.

Take the other end of the power cord and plug it into a wall outlet.

On the back side of the machine, turn the ON/OFF switch to the ON position. (After a couple of seconds, the Top Cover will automatically open.)

Leave the Top Cover in the open position.

3. Fill Reservoir with Water:

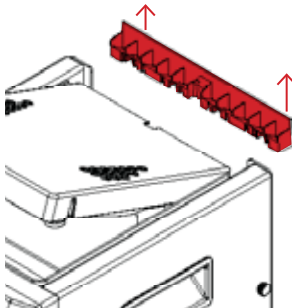

Remove the Lid Stopper.

Locate the Platen Assembly and remove from the machine by pulling up.

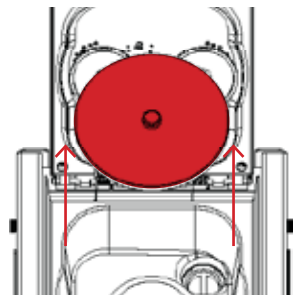

Initial Setup ... continued

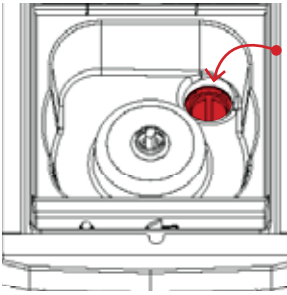

Towards the back right hand corner of the Catch Tray is a drain that connects to the water reservoir. Pour about 750mL (or 2 cups) of water into this area.

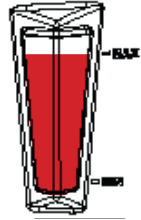

Watch the visual water display on the front of the machine as you fill the reservoir with water.
(DO NOT FILL WATER PAST THE "MAX" FILL LINE!)

Reinstall the Platen Assembly.

4. Prep the Water Line:

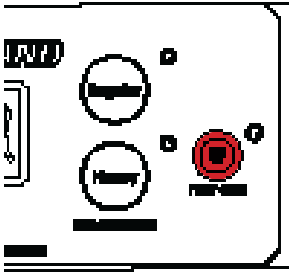

Warning: Failure to prep the Water Line will cause damage to the disc!

The cover must be in the open position to perform these steps.

Have a paper towel or small container ready, in order to catch the Water, which will come from the tube nozzle.

Locate the small button, labeled "W", on the front User Keypad. To activate the prepping process, press the "W" button.

Once the prepping process has been activated, tilt the Top Cover down toward you, at about a 45 degree angle. (Note: Make sure that the Platen Assembly is installed, so that water does not pour directly onto the shaft of the main motor!) This will ensure that the water drips out of the nozzle and onto the napkin, instead of running down the inside lid cover.

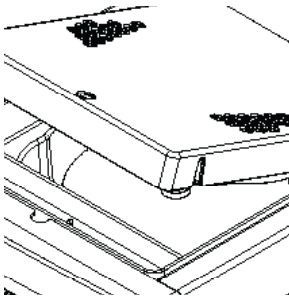

5. Install the Center Hub:

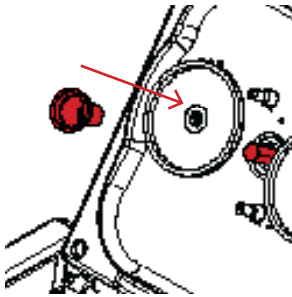

Locate the Hex shaped post between the two Sanding Pad holders.

Take a Center Hub and line up the hex shaped opening on the hub with the hex shaped post.

Push the Center Hub into place.

Spin the Center Hub by hand to make sure that the hub is centered. If needed, make an adjustment.

6. Install the Foam Pads:

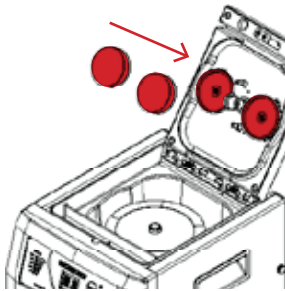

Locate the two Sanding Pad Holders.

Take one set of new Foam Pads and install each Foam Pad onto the Sanding Pad Holders. Make sure that each Foam Pad is centered and fully seated on the Sanding Pad Holder.

Caution: It is essential to keep the Top Cover in the Open position when the machine is in the “Stand By” mode and when the machine is not in use! This will ensure that the Foam Pads will not become flat, which would affect the sanding process, and would cause an error message to display. If you would like to keep the Top Cover closed when the machine is not in use, make sure to remove the Platen Assembly.

7. Install Sanding Pads:

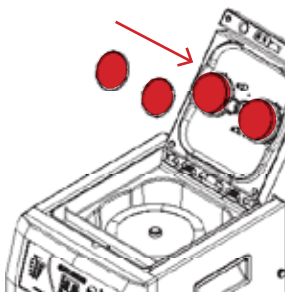

Take one set of new Sanding Pads and install each Sanding Pad onto the Foam Pads. Make sure that each Sanding Pad is centered and fully seated on the Foam Pads.

Reinstall the Lid Stopper.

Your VMI Quicksand unit is now ready to be used!

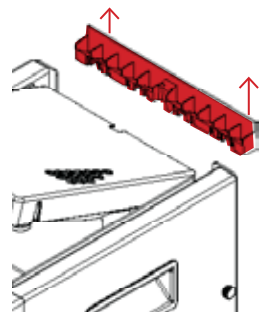

How to use your machine

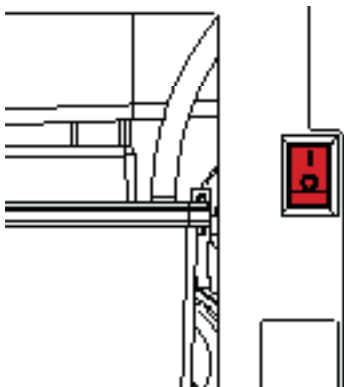

1. Turn ON power to the unit by pressing the ON/OFF switch to the ON position, located in the rear of the unit. The Top Cover will open automatically after a few seconds.

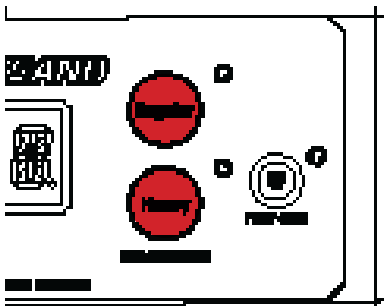

2. Select the mode that you would like to sand your disc for, depending on the severity of damage, by selecting either the Regular or Heavy option – located on the User Keypad.

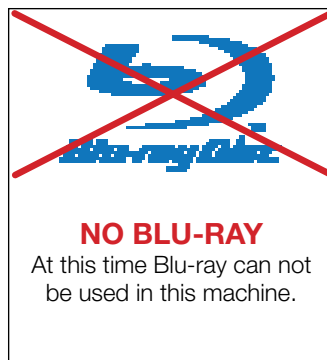
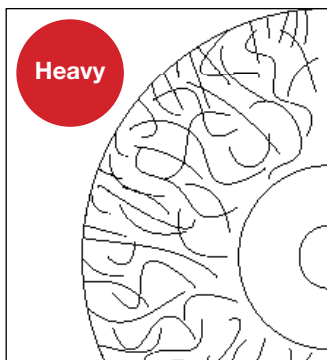

How to use your machine

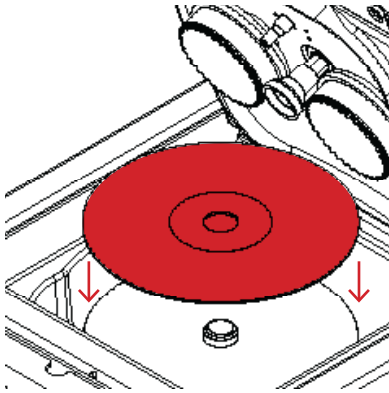

3. Place disc onto the Platen Assembly, with LABEL SIDE OF DISC FACING DOWN!

CAUTION: DO NOT PLACE BLU-RAY DISCS INTO THIS MACHINE! THEY WILL BE DAMAGED!

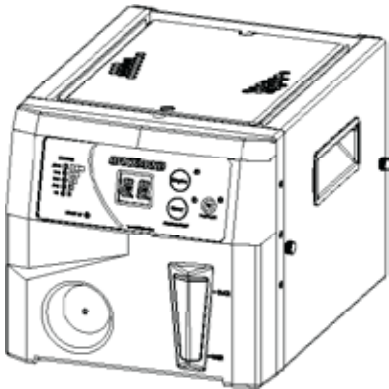

4. Close the Top Cover and the cycle will start automatically.

5. Once the cycle has completed, the Top Cover will open automatically. Remove your disc, wipe it of any residue, and proceed to the final repair on one of VenMill Industries' disc repair models.

Modes of Operation

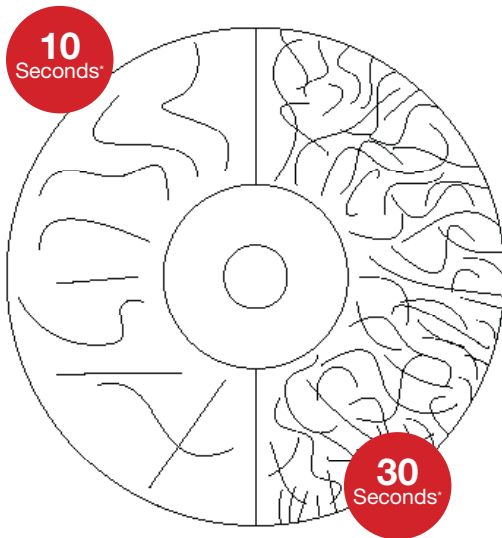

Regular: 10 Seconds

This option is ideal for all discs, except Blu-ray.

Press the “Regular” button located on the User Keypad to activate this operation. Next, close the Top Cover, and the machine will start automatically.

Heavy: 30 Seconds

This option is ideal for all discs, except Blu-ray.

Press the “Heavy” button located on the User Keypad to activate this operation. Next, close the Top Cover, and the machine will start automatically.

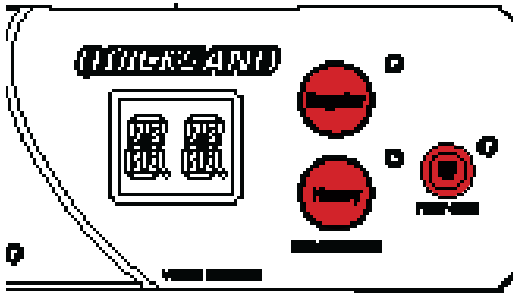

Emergency Stop: At any time during a cycle, you may stop the cycle prematurely, by pressing any button on the User Keypad. Once the button is pressed, the cycle will stop, and the Top Cover will open automatically. The Main Screen will then display the “ER” error message indicating that the Emergency Stop function has been successfully accomplished. Once the unit has reset, the “ER” error message will disappear, and the machine will default back to the last mode of operation that was selected. The Operator may now continue using the machine.

Replace All Consumables (RC):

The CQ Chip has been designed to monitor the consumables used within your VMI Quicksand, to ensure that each disc is repaired to the same standard, and to decrease any downtime that may result from not having replacement consumables on hand. Installation of a new CQ Chip informs the unit that the consumables have been replaced. The amount of consumable usage is displayed on the “Supplies – Fuel Gauge” located on the User Keypad. As the consumables deplete over time, the Fuel Gauge will expire down in percentage as follows:

100% = 100 minutes

75% = 75 minutes

50% = 50 minutes

25% = 25 minutes

0% = 0 minutes

Once the consumable level has reached 25%, the Green LED will switch over to Yellow, and the 0% Green LED will turn over to Red and will blink every two seconds. At this point the Operator should make plans to obtain more consumables. Once the CQ Chip has reached 0%, the flashing Red LED will stop and a solid Red LED will appear. At this point the “RC” error message will appear on the Main Screen. The machine will not perform any other operations until a new CQ Chip is installed.

Once a new CQ Chip has been installed and power to the machine is turned back on, then the “RC” error message on the Main Screen will disappear. Fuel Gauge will display 100%. The machine is now ready to resume operation.

Error Messages:

E1: Top Cover Closed / Switch still Activated.

E2: Main Motor is not achieving enough current.

E3: Main Motor is achieving too much current.

E5: Water Pump is not working.

ER: Emergency Stop.

Required Actions:

CP: Replace Sanding Pads, Clean Filter, and Check & Add Water

RC: Replace all Consumables and clean out machine.

Standard Maintenance

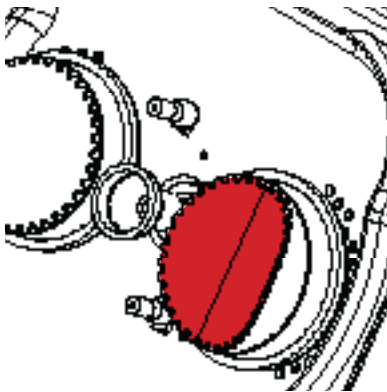
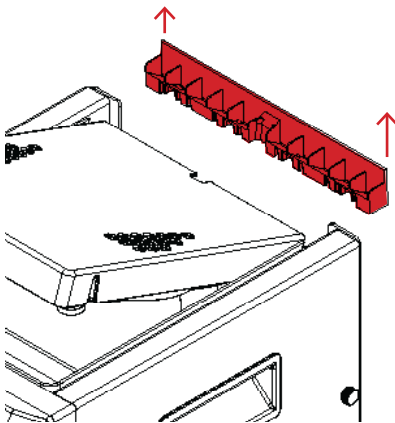
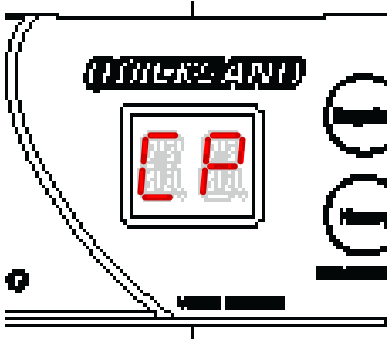

How to Replace the Sanding Pads

The machine will notify the Operator to replace the Sanding Pads by displaying the “CP” message after 25 minutes of machine operation.

1. Remove the Lid Stopper from the back of the Top Cover.
2. Make sure the Top Cover is in the “Open” position.
3. Locate the Sanding Pads.
4. Pull back gently with your finger and thumb on any outside edge on the Sanding Pad. Pull the Sanding Pad away from the Foam Pad, until the pad is completely detached.
5. Repeat step #3 for the second Sanding Pad.
6. Take your new Sanding Pad and line it up with the Foam Pad. It is essential that the Buffering Pad CENTERED on the Foam Pad. Make sure that the new Sanding Pad is fully seated and on the Foam Pad by pressing gently on the entire surface of the pad.
7. Repeat step #5 for the second Sanding Pad.
8. Reinstall the Lid Stopper.
9. Press the “Regular” and then the “Heavy” buttons on the User Keypad to inform the machine that the Sanding pads were replaced.

How to Clean the Filter *(See image on page 15)*

The filter for the water reservoir must be cleaned at the same time as replacing the Sanding Pads, when the machine gives off the “CP” message. This will occur after 25 minutes of machine operation.

1. Remove the Lid Stopper from the back of the Top Cover.
2. Let the Top Cover gently open to its farthest position.
3. Pull off the Platen from the Main Motor shaft.

Standard Maintenance

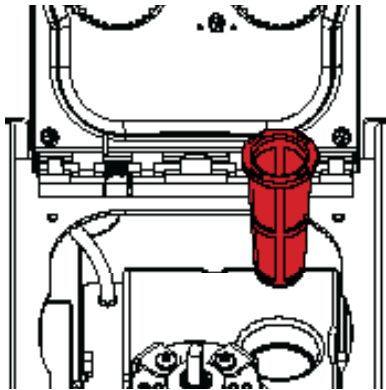

4. Locate the removable Catch Tray. Pull up on the outer edges of the tray and remove from the machine.
5. Locate the Water Reservoir and the opening for the filter. Pull the filter out of the reservoir.
6. Rinse the filter under warm water until all of the plastic remnants are washed away.
7. Reinstall the filter and catch tray.
8. Check the level of water inside of the reservoir by looking at the water display on the front of the machine. If the water level is low, please replenish the water. (DO NOT FILL WATER PAST THE “MAX” FILL LINE!)
9. Reinstall the Platen onto the shaft of the Main Motor.
10. Reinstall the Lid Stopper.

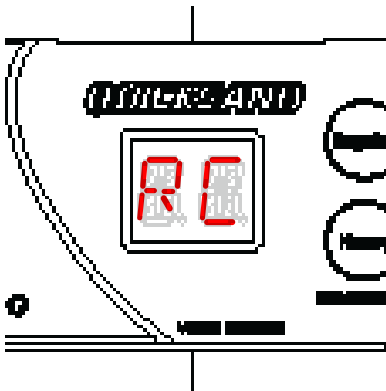

How to Replace the Foam Pads

The machine will notify the Operator to replace the foam Pads by displaying the “RC” message.

1. Make sure the Top Cover is in the “Open” position.
2. Locate the Foam Pads.
3. Pull back gently with your finger and thumb on any outside edge of the Foam Pad. Pull the Foam Pad away from the Foam Pad Holder, until the pad is completely detached.
4. Repeat step #3 for the second Foam Pad.
5. Take your new Foam Pad and line it up with the Foam Pad Holder. It is essential that the Foam Pad is CENTERED on the Foam Pad Holder. Make sure that the new Foam Pad is fully seated on the Foam Pad Holder by pressing gently on the entire surface of the pad.
6. Repeat step #5 for the second Foam Pad.
7. Install a new set of Sanding Pads.

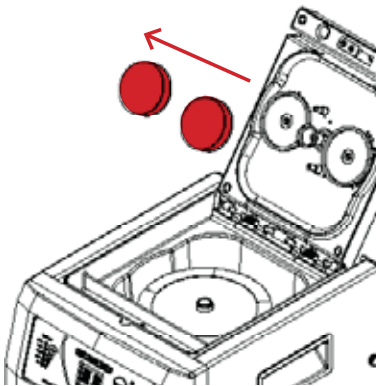

Standard Maintenance

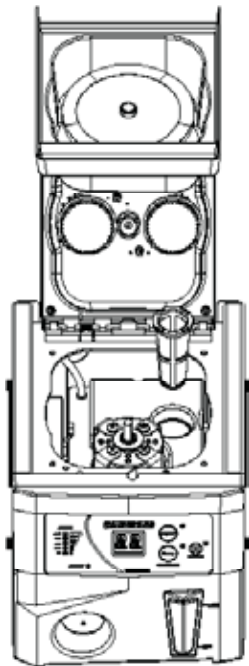
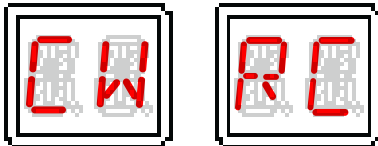
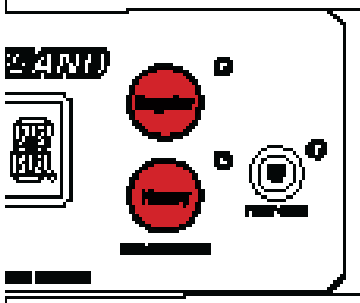

How to Clean the Water Reservoir

Cleaning of the Water Reservoir must be done when the machine displays the “RC” message.

1. Remove the Lid Stopper from the back of the Top Cover.
2. Let the Top Cover gently open to its farthest position.
3. Pull off the Platen from the Main Motor shaft.
4. Locate the removable Catch Tray. Pull up on the outer edges of the tray and remove from the machine.
5. Locate and pull down on the Back Panel Door, on the rear of the machine, to expose the Water Reservoir.
6. Looking in on the rear of the machine, located on the right hand side of the reservoir, is the feed for the water tubing. Remove this tube from the reservoir.
7. Pull the Water Reservoir out of the machine.
8. Remove the filter from the reservoir and clean it under warm water.
9. Remove the reservoir clips and pull the top part of the reservoir from the bottom.
10. Pour out and dispose of the water from the reservoir. Wash the inside of the reservoir with warm water until all of the plastic remnants are washed away.
11. Put the reservoir back together and reinstall the clips. Insert the reservoir into the machine and reconnect the water feed tube.
12. Reinstall the Catch Tray.
13. Towards the back right hand corner of the Catch Tray is a drain that connects to the water reservoir. Pour about 750mL of water into this area.
14. Watch the visual water display on the front of the machine as you fill the reservoir with water.
(DO NOT FILL WATER PAST THE “MAX” FILL LINE!)

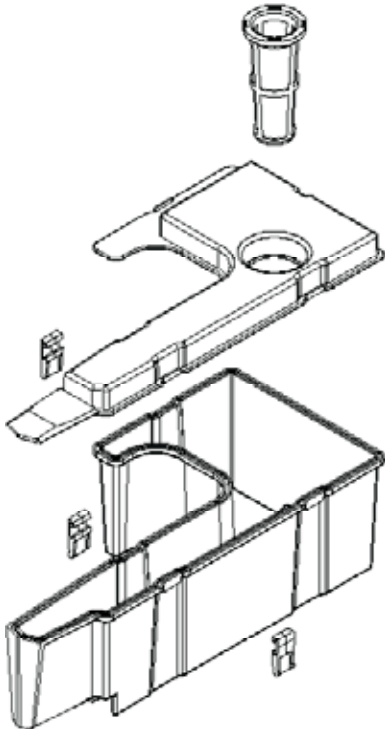

15. Reinstall the Platen.
16. Reinstall the Lid Stopper.
17. No further action is required, unless other consumables need to be replaced.

How to Replace the Center Hub

The Center Hub must be replaced at the same time that all the other consumables are being replaced due to the “RC” message.

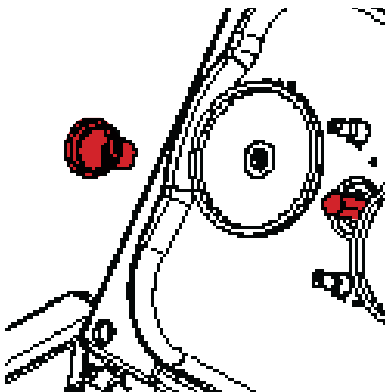

1. Make sure the Top Cover is in the “Open” position.
2. Locate the Center Hub.
3. Pull the used Center Hub off of the Hex shaped post with your Index Finger and Thumb.
4. Take the new Center Hub and line up the Hex shaped opening on the hub with the Hex shaped post.
5. Push the Center Hub onto the post.
6. Spin the Center Hub by hand to make sure the Hub is centered. If needed, make the proper adjustment.

Standard Maintenance

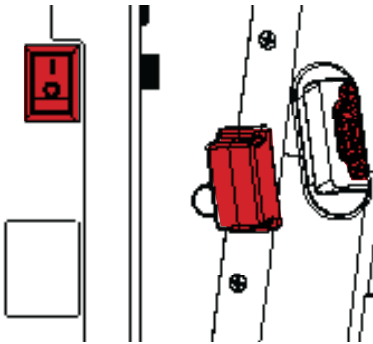

How to Replace the Consumable Counter Chip (CQ Chip)

The machine will notify the Operator to replace the CQ Chip, after 100 or 50 minutes (depending on the specific combo pack configuration), by displaying the “RC” message. All consumables must be replaced at this time!

1. Turn OFF power to the unit.
2. Locate the RS232 port on the front left hand side of the machine.
3. Remove the depleted CQ Chip.
4. Take a new CQ Chip and install it into this port.
5. Once the new CQ Chip has been installed and the machine is powered back on, the “RC” message on the Main Screen will disappear, and the “Supplies – Fuel Gauge” will display 100%.

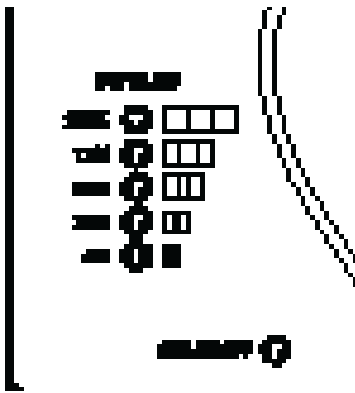

How to Replace the Jet Nozzle Extenders

The Jet Nozzle Extenders must be replaced at the same time that all the other consumables are being replaced due to the “RC” message.

1. Make sure the Top Cover is in the “Open” position.
2. Locate the two Jet Nozzle Extenders.
3. Pull the worn Extenders off of the Jet Nozzles with your Index Finger and Thumb.
4. Take a new Extender and line up one end with the Jet Nozzle spout.
5. Push the Extender onto the Jet Nozzle spout.
6. Repeat steps #4 and #5 for the second Extender.

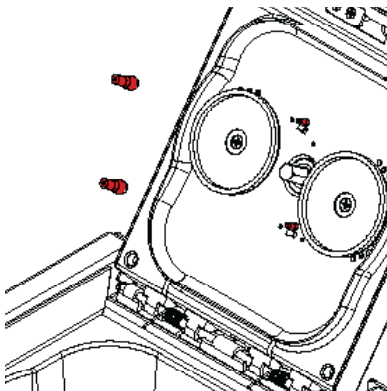

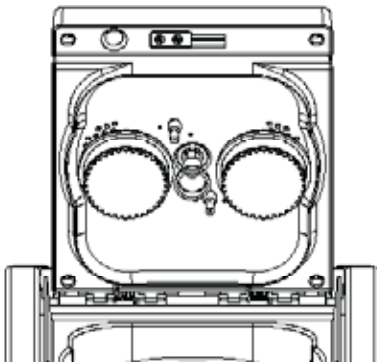
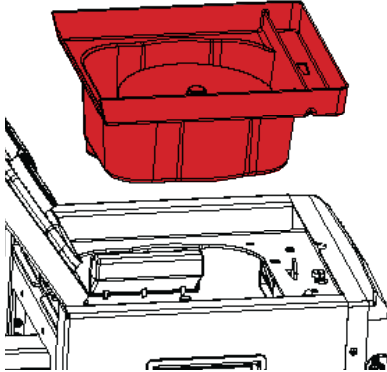
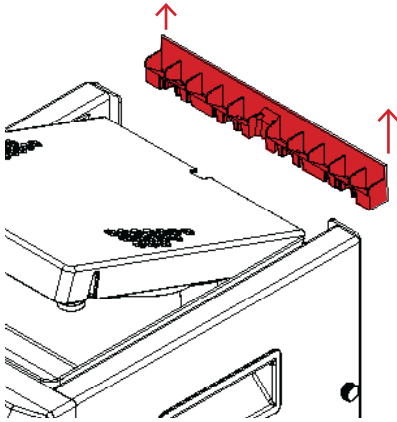

How to Clean the Catch Tray

Over time your Catch Tray may build up with plastic residue from the Sanding Process. There is no set time for when this item needs to be cleaned. It is up to the Operator's discretion to decide when to perform this task. However, we strongly recommend at least cleaning the Catch Tray every time a new set of consumables is installed.

1. Make sure the Top Cover is in the "Open" position.
2. Remove the Lid Stopper from the back of the Top Cover.
3. Let the Top Cover gently open to its farthest position.
4. Pull off the Platen from the Main Motor shaft.
5. Locate the removable Catch Tray. Pull up on the outer edges of the tray and remove from the machine.
6. Rinse the Catch Tray under warm water until all of the plastic remnants are washed away.
7. Make sure that the Catch Tray is dry before reinstalling into the machine.
8. Reinstall the Catch Tray.
9. Reinstall the Platen onto the shaft of the Main Motor.
10. Reinstall the Lid Stopper.

What to do when the Quicksand will not be used for an extended period of time

Make sure to keep the Top Cover in the "Open" position. This will ensure that the Foam Pads will not become flat. **CAUTION: FLAT PADS WILL PRODUCE INFERIOR RESULTS AND MAY CAUSE COMPLICATIONS.**

Note: If you desire to keep the Top Cover in the "Closed" position while not in use, remove the Platen from the machine.

Repacking

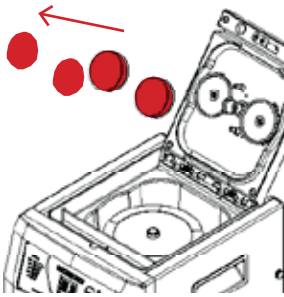

1. Remove the Foam Pads, along with the attached Sanding Pads, from the inside of the machine.
2. Empty the Water Reservoir.
3. Drain the Water tubing.

Note: For the Water line, press the “W” button on the front User Keypad. Have a small container ready to catch the draining water. Once all the water has been drained, press the “W” on the front User Keypad to stop the drainage.

WARNING: FAILURE TO REMOVE ANY WATER FROM THE MACHINE AND FAILURE TO DRAIN THE WATER LINE FOR SHIPPING WILL RESULT IN POTENTIAL DAMAGE TO YOUR VMI QUICKSAND! THE RESULTING DAMAGE IS NOT COVERED BY THE WARRANTY AGREEMENT.

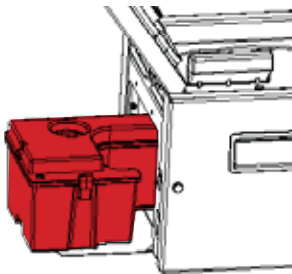

4. Turn off power to the machine.
5. Close the Top Cover.
6. Remove the power cord.
7. Place the VMI Quicksand into the protective plastic bag.
8. Place the machine into the left and the right packing foams.
9. Place the Quicksand into the Shipping Box.
10. Place the Top Cardboard Insert back into position.
11. Insert anything else that has been required by the Technical Support Department.
12. Close and tape the Shipping Box.
13. Write the provided RMA number on the outside of the Shipping Box.

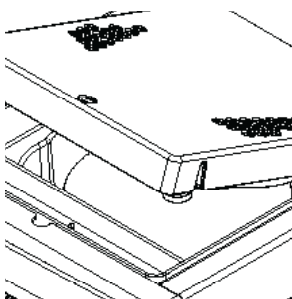
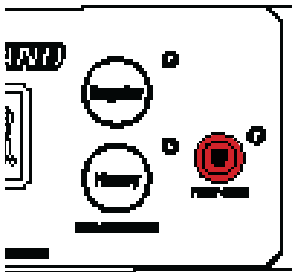

Note: In order to send a machine in for servicing, a customer must call Technical Support first (866-864-0210) to troubleshoot the unit. If an authorized technician deems that the machine is in need of servicing, they will provide the customer with an RMA form to fill out. Any machine sent in without authorization may be refused and will be returned to the customer at their expense.

For further assistance with questions not included please refer to our website at www.venmill.com

1. Why do I have to keep the Top Cover in the open position when my VMI Quicksand is not in use?

Leaving the Top Cover in the closed position for a prolonged period of time, without running the machine, will cause the Foam Pads to become flat. When this happens the Foam Pads will not be able to sand the discs properly. If you would like to keep the Top Cover closed, when the machine is not in use, remove the Platen Assembly from the machine.

2. Can I sand a 3 inch disc?

No!

3. Can I sand a Blu-ray disc?

No! Due to the nature of Blu-ray discs, where the data layer is so close to the surface of the optical side of the discs, this sanding process is too aggressive and will damage the data layer. For maintenance and repair of Blu-ray discs, we strongly recommend repairing them on the VMI Hybrid disc repair machine.

4. Can I sand a Double-Sided disc?

Yes!

5. Can I sand a disc that is warped or cracked?

No!

6. When should I replace my Platen?

There is no set life expectancy for the Platen. If you notice any imperfections, such as rips, tears, nicks, gouges, worn spots, and/or missing material – then the Platen should be replaced. You may order consumables through VenMill directly at www.venmill.com, or through one of our current distributors located on our website under the Distributors tab. If you have any questions, please contact us at 800-928-0090 / 866-864-0210 Intl. or email Sales@venmill.com.

7. Can I run my VMI Quicksand over 100 or 50 minutes without replacing the CQ Chip?

No! Once the CQ Chip is depleted the unit will not allow for any more cycles to be run. Once a new CQ Chip has been installed, the machine will continue with normal operation.

8. Why do I have to remove the Water from the machine for shipping?

Since VenMill Industries cannot control how your VMI Quicksand is handled when in transit, we ask that you remove all traces of water from the machine, so that no water leaks into the machine during shipping. Water leakage will cause damage to the internal components.

9. What should I do with the leftover water on my discs?

Due to the nature of the Quicksand sanding process, water will be left on the surface of the disc, at the end of the cycle. It is recommended

FAQs

that you try to pour any large quantities of water back into the Catch Tray. Any remaining water on the disc should be wiped away with a towel to ensure that any remaining plastic remnants on the disc are removed. The VMI Quicksand is designed to work optimally with the VMI Hybrid. Cleaning the disc of all plastic particles will ensure that the Hybrid Buffing Pads are not contaminated with plastic particles.

10. What should I do if I notice an inferior/inconsistent sanding, before the life expectancy of my Sanding Pads have yet to be met?

If the Sanding Pads are not installed properly or they have not been completely seated on the Foam Pads, then this can cause the Sanding Pads to shift their position during the sanding process, so that they are now off-center. Off-center pads will result in an inferior/inconsistent sanding pattern. Simply remove the Sanding Pads from the Foam Pads and reinstall. Make sure that the Sanding Pads are completely centered and that they are full pressed onto the Foam Pads.

11. Is it important to keep my Platen Assembly clean?

Yes! The cleaner you keep your Platen Assembly the longer it will last. It is also possible that if water is allowed to build up on the surface of the Platen that this can cause the surface to become slick which would allow the disc to spin during the sanding process. This could cause damage to the disc. Since there is plastic residual mixed in with the water around the sanding area, this residual if left on the Platen, could cause scratches on the label side of the disc.

12. Is it important to keep the Sanding Pads free of plastic particals?

Yes! For optimal results keep the sanding pads clean of plastic residue particules.

Disconnect unit from supply circuit before opening!

Warning and Cautions:

You are cautioned that any changes or modifications not expressly approved in this manual could void your warranty.

If you have any questions about this product, contact VenMill Industries at 800.928.0090 USA or 866.864.0210 Canada.

Special Feature: Emergency Quick Release

If at any time you need to manually release the Top Cover, you can do so by using any object such as a pencil or pen, to release the latch.

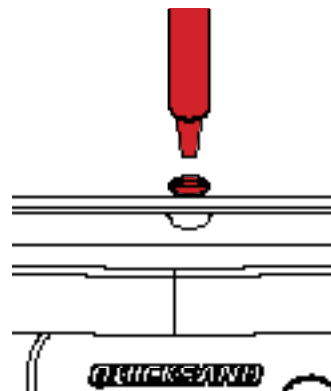
**Safety Features:**

- Removable power cord
- ON/OFF Switch
- Process controlled to prevent operation when Top Cover is in the opened position
- Emergency Stop with any button activation or release of the latch for the Top Cover

Specifications:

Unit operates on 24 Volt DC power.

Weight: 8.5kgs

Dimensions: 8.7"W x 11.2"L x 7.85"H

Power: Safe DC Power

Part Number: PNV6500 / PNV6550i-EU / PNV6550i-AU

Warranty: 1 Year Limited

FOR SUPPORT INFORMATION

www.reface.com.au

or

1800REFACE

1800733223

MAILING ADDRESS:

107 Kew Street

Welshpool

WA 6061